

# ADVANCE ADAPTERS INC.

P.O. Box 247, 4320 Aerotech Center Way

Paso Robles, CA 93447

Telephone: (800) 350-2223 Fax: (805) 238-4201

## P/N: 712566

PAGE 1 OF 3

Page Rev. Date: 05-09-05

## JEEP PEUGEOT 5 SPEED TRANSMISSION TO CHEVY & BUICK ENGINES

### KIT CONSISTS OF:

No.	Qty	Part No.	Description
1.	1	712566-BLK	FULL BELLHOUSING ADAPTER
2.	1	712567-PLT	DUST COVER
3.	1	716170	PILOT BUSHING
4.	1	716214	JEEP PEUGEOT HYDRAULIC RELEASE BRG (Jeep #83503383)
5.	4	722542	#10 x 1/2" SELF TAPPING SCREWS
6.	6	723740	S.H.C.S. 3/8"-16 x 1-1/2" LG.
7.	1	JP001	JEEP INSTRUCTION MANUAL

*Most 1999 & up GM V8 & V6 engines had a larger crank I.D. The pilot bushing in this kit requires a steel sleeve (P/N 716155), or you can also use a new GM bearing (P/N 12557583).*

### INSTALLATION INSTRUCTIONS:

This bellhousing is not compatible with transmissions that were previously equipped with diesel engines. The new bellhousing design incorporates the exclusive use of the original Jeep internal hydraulic release bearing assembly. The new bearing will need to be installed on the front of the transmission with the nylon straps in position. **DO NOT REMOVE THE NYLON STRAPS PRIOR TO ASSEMBLY.** Make sure that the new bearing is positioned over the front of the Peugeot transmission properly. The steel lines will need to be bent so that they exit through the Advance Adapter bellhousing hole. If the new bearing assembly is not properly fitted to the front of the transmission, the bearing assembly will be angled causing seal failure. On most applications, you will need to grind the necessary clearance on the inside of the bellhousing in order for the bearing to sit in the proper position.

This bearing assembly must be used with a high profile Centerforce pressure plate. Make sure the bearing assembly does not bottom out against the clutch fingers prior to bleeding of the slave cylinder installation. The original Jeep pressure plate can be reused with the new GM flywheel. However, you must double check the deck height of the fingers versus the bearing height to make sure the necessary clearance is obtained. The only way to develop additional clearance between the clutch fingers and bearing height is to machine the flywheel thickness. We had an experienced of a customer that used a flywheel that was 1-1/8" thick and during assembly, he developed a 1/8" interference between the fingers and the bearing. This interference created severe friction and caused premature seal failure. Take the extra time to measure the bearing height and finger height and allow for a minimum of 1/16" clearance.

**SPECIAL NOTE:** The components packaged in this kit have been assembled and machined for specific type of conversions. Modifications to any of the components will void any possible warranty or return privileges. If you do not fully understand modifications or changes that will be required to complete your conversion, we strongly recommend that you contact our sales department for more information. This instruction sheet is only to be used for the assembly of Advance Adapter components. We recommend that a service manual pertaining to your vehicle be obtained for specific torque values, wiring diagrams and other related equipment. These manuals are normally available at automotive dealerships and parts stores.

## ADVANCE ADAPTERS INC.

P.O. Box 247, 4320 Aerotech Center Way

Paso Robles, CA 93447

Telephone: (800) 350-2223 Fax: (805) 238-4201

P/N: 712566

PAGE 2 OF 3

Page Rev. Date: 08-10-09

# JEEP PEUGEOT 5 SPEED TRANSMISSION TO CHEVY & BUICK ENGINES

### **Make sure the tip of the input shaft has sufficient engagement into the pilot bushing.**

1. Install the pilot bushing into the engine crank.
2. Install the flywheel, pressure plate & clutch disc onto engine using the correct flywheel and clutch bolts.
3. With the clutch and flywheel assembled, measure the deck height of the clutch fingers. This height should be approximately 3.875" to 3.937".
4. Install the new Jeep release bearing onto the front of the Peugeot transmission. Make sure that the hole on the front of the transmission lines up with the plastic retainer cap. This small split pin will prevent the retainer from rotating inside the bellhousing. **DO NOT REMOVE PLASTIC STRAPS.** Make sure that new bearing assembly fits properly onto front of transmission without any binding of the hydraulic lines.
5. Assemble the transmission to the bellhousing using the original bolts and dowel pins.
6. With the bearing in position on the front of the transmission and the bellhousing bolted to the transmission, you will need to measure the bearing height from the engine face of the bellhousing. This distance must be approximately 4" allowing for 1/8" clearance between bearing and clutch fingers.
7. If the clearance between the bearing and clutch fingers is not provided, you will need to machine the flywheel to a thinner measurement that will provide the necessary clearances.
8. Assemble the bellhousing over the clutch assembly. Make sure the bearing face has clearance between the fingers and bearing surface. Premature collapsing of the slave cylinder assembly will damage the internal components. The face of the bearing must have clearance between the fingers prior to bleeding.
9. The hydraulic line between the Jeep master cylinder and the new Jeep hydraulic slave cylinder will need to be assembled together.
10. Bleed the slave cylinder assembly.
11. Check to make sure that the slave cylinder is fully disengaging the clutch plate. If you have any difficulties obtaining the necessary travel, contact Advance Adapters immediately.

### **DUST COVER INSTALLATION:**

*Prior to transmission assembly, we recommend test fitting and assembly of the dust cover onto the bellhousing. Two of the 4 holes have already been drilled for self tapping screws. The lower two holes will need to be drilled for 2 self tapping screws. The drill size should be 11/64 (.171 Diameter) approximately 1/2" deep. On some applications the new hole may enter the slave cylinder mounting hole.*

**SPECIAL NOTE:** The components packaged in this kit have been assembled and machined for specific type of conversions. Modifications to any of the components will void any possible warranty or return privileges. If you do not fully understand modifications or changes that will be required to complete your conversion, we strongly recommend that you contact our sales department for more information. This instruction sheet is only to be used for the assembly of Advance Adapter components. We recommend that a service manual pertaining to your vehicle be obtained for specific torque values, wiring diagrams and other related equipment. These manuals are normally available at automotive dealerships and parts stores.

# ADVANCE ADAPTERS INC.

P.O. Box 247, 4320 Aerotech Center Way

Paso Robles, CA 93447

Telephone: (800) 350-2223 Fax: (805) 238-4201

# P/N: 712566

PAGE 3 OF 3

Page Rev. Date: 01-11-94

## JEEP PEUGEOT 5 SPEED TRANSMISSION TO CHEVY & BUICK ENGINES

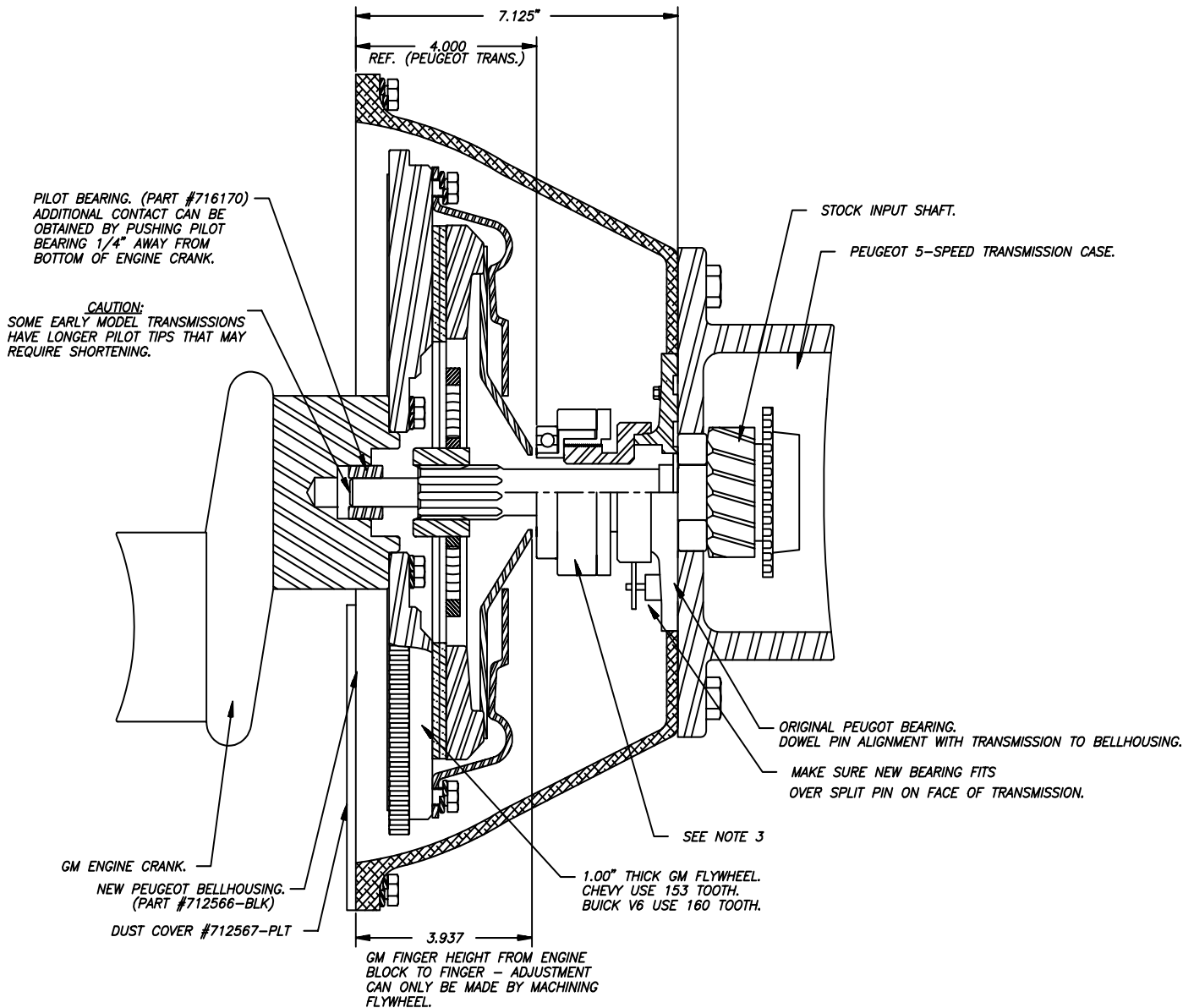

**SPECIAL NOTE:** The components packaged in this kit have been assembled and machined for specific type of conversions. Modifications to any of the components will void any possible warranty or return privileges. If you do not fully understand modifications or changes that will be required to complete your conversion, we strongly recommend that you contact our sales department for more information. This instruction sheet is only to be used for the assembly of Advance Adapter components. We recommend that a service manual pertaining to your vehicle be obtained for specific torque values, wiring diagrams and other related equipment. These manuals are normally available at automotive dealerships and parts stores.