

ADVANCE ADAPTERS INC.

P.O. Box 247, 4320 Aerotech Center Way

Paso Robles, CA 93447

Telephone: (800) 350-2223 Fax: (805) 238-4201

P/N: 716807

PAGE 1 OF 4

Page Rev. Date: 05-05-08

MANUAL STEERING CONVERSION TOYOTA LAND CRUISER NEW DESIGN JAN '97

KIT CONSISTS OF:

No.	Qty	Part No.	Description
1.	2	716812	CLAMP (FOR NEW TIE ROD)
2.	1	716814	CLAMP (For Spud Shaft)
3.	1	716816	PITMAN ARM-MANUAL
4.	1	716821	NEW TIE ROD END FOR NEW TIE ROD
5.	1	716822	MOUNTING PLATE FOR COLUMN TO FLOORBOARD
6.	1	716831	SPECIAL TIE ROD WITH METRIC TOYOTA THREAD
7.	1	716832	GUSSET-FRAME TO MOUNTING PLATE
8.	1	716833	NEW COLUMN BEARING ASSEMBLY (VEHICLES '73 & NEWER)
9.	1	716834-30B	SPUD SHAFT WITH 30 TEETH INTERNAL
10.	1	716839 Kit	STEERING BOX MOUNTING PLATE w/ <i>Passenger side frame enclosure</i>
11.	1	716851	3/4" DD X 3/4" DD UNIVERSAL YOKE ASSY.
12.	1	716862	DOUBLE SLIP SHAFT W/ GREASE FITTING/SLIP YOKE
13.	4	720064	8mm x 1.25 x 30mm H.H.C.S. (<i>Column bearing bolts</i>)
14.	4	720065	8mm x 1.25 HEX NUT (<i>Column bearing nuts</i>)
15.	4	723103	LOCK WASHER (<i>Column bearing</i>)
16.	4	723735	FLAT WASHER (<i>Column bearing</i>)
17.	1	723703	NYLON LOCK NUT 3/8"-16
18.	1	723725	H.H.C.S 3/8"-16 x 2"
19.	1	TLC001	LANDCRUISER INSTRUCTION MANUAL

**Kit does not include the Saginaw Steering Box or Steering Hoses.

Advance Adapters has been manufacturing steering conversion parts for installation of the Saginaw steering boxes into Toyota vehicles for more than twelve years. The parts we furnish are of the highest quality available and we utilize only proven design components for our kits. Before you consider the conversion, we recommend that you thoroughly read and understand the complete procedure (*located in the Land Cruiser Manual*). **Do not take short cuts on steering installations.** We recommend that these conversions be installed by a qualified technician. All universal joints must be safety wired for double protection. **Do not overlook any details. Remember that the control of your vehicle depends on the steering gear performance. Failure of your steering system can result in severe damage and possible injury.**

SPECIAL NOTE: The components packaged in this kit have been assembled and machined for specific type of conversions. Modifications to any of the components will void any possible warranty or return privileges. If you do not fully understand modifications or changes that will be required to complete your conversion, we strongly recommend that you contact our sales department for more information. This instruction sheet is only to be used for the assembly of Advance Adapter components. We recommend that a service manual pertaining to your vehicle be obtained for specific torque values, wiring diagrams and other related equipment. These manuals are normally available at automotive dealerships and parts stores.

ADVANCE ADAPTERS INC.

P/N: 716807

P.O. Box 247, 4320 Aerotech Center Way

Paso Robles, CA 93447

Telephone: (800) 350-2223 Fax: (805) 238-4201

PAGE 2 OF 4

Page Rev. Date: 07-12-00

MANUAL STEERING CONVERSION TOYOTA LAND CRUISER NEW DESIGN JAN '97

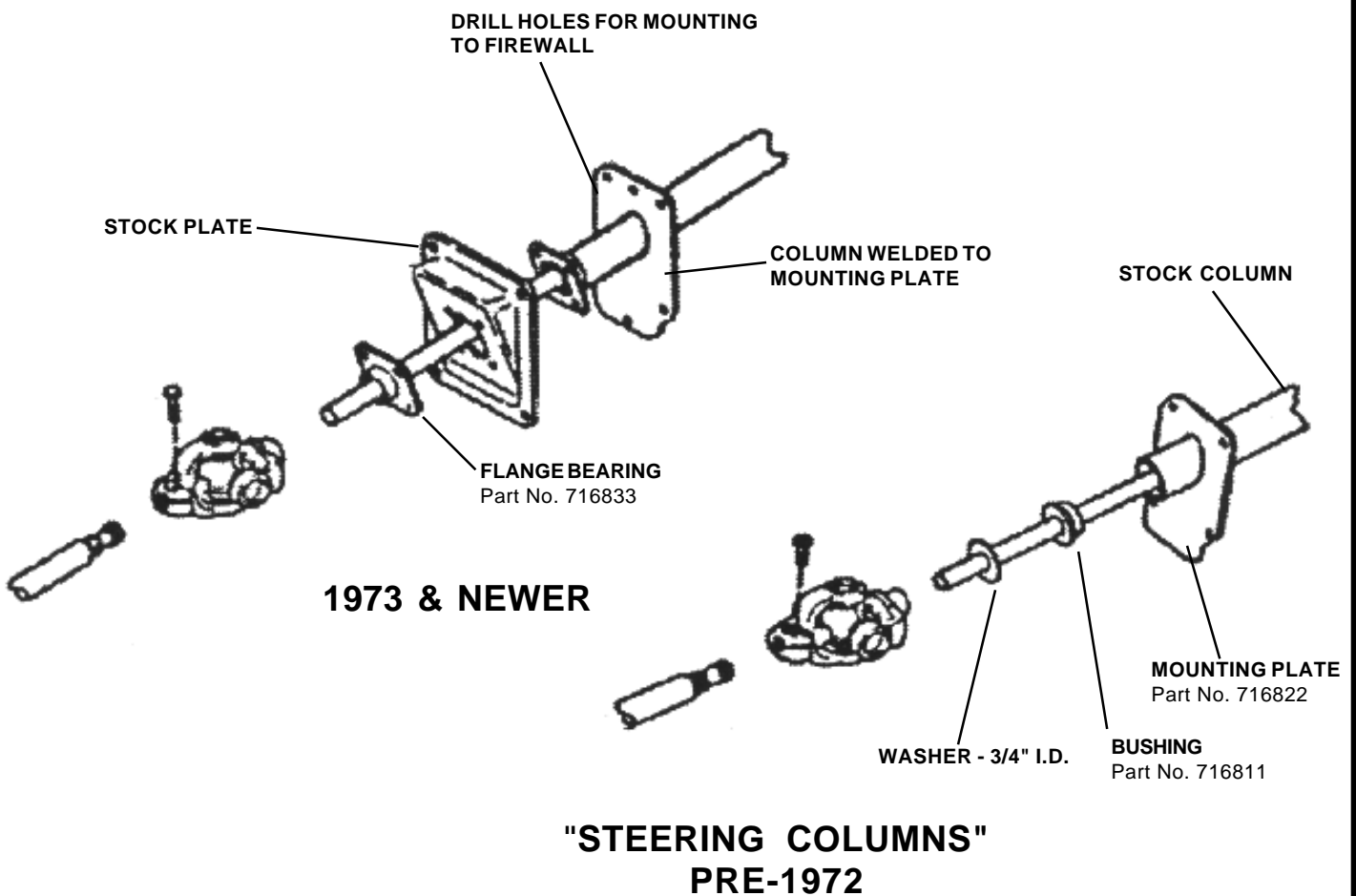

SPECIAL NOTE: The components packaged in this kit have been assembled and machined for specific type of conversions. Modifications to any of the components will void any possible warranty or return privileges. If you do not fully understand modifications or changes that will be required to complete your conversion, we strongly recommend that you contact our sales department for more information. This instruction sheet is only to be used for the assembly of Advance Adapter components. We recommend that a service manual pertaining to your vehicle be obtained for specific torque values, wiring diagrams and other related equipment. These manuals are normally available at automotive dealerships and parts stores.

ADVANCE ADAPTERS INC.

P.O. Box 247, 4320 Aerotech Center Way
Paso Robles, CA 93447

Telephone: (800) 350-2223 Fax: (805) 238-4201

P/N: 716807

PAGE 3 OF 4

Page Rev. Date: 06-21-02

MANUAL STEERING CONVERSION TOYOTA LAND CRUISER NEW DESIGN JAN '97

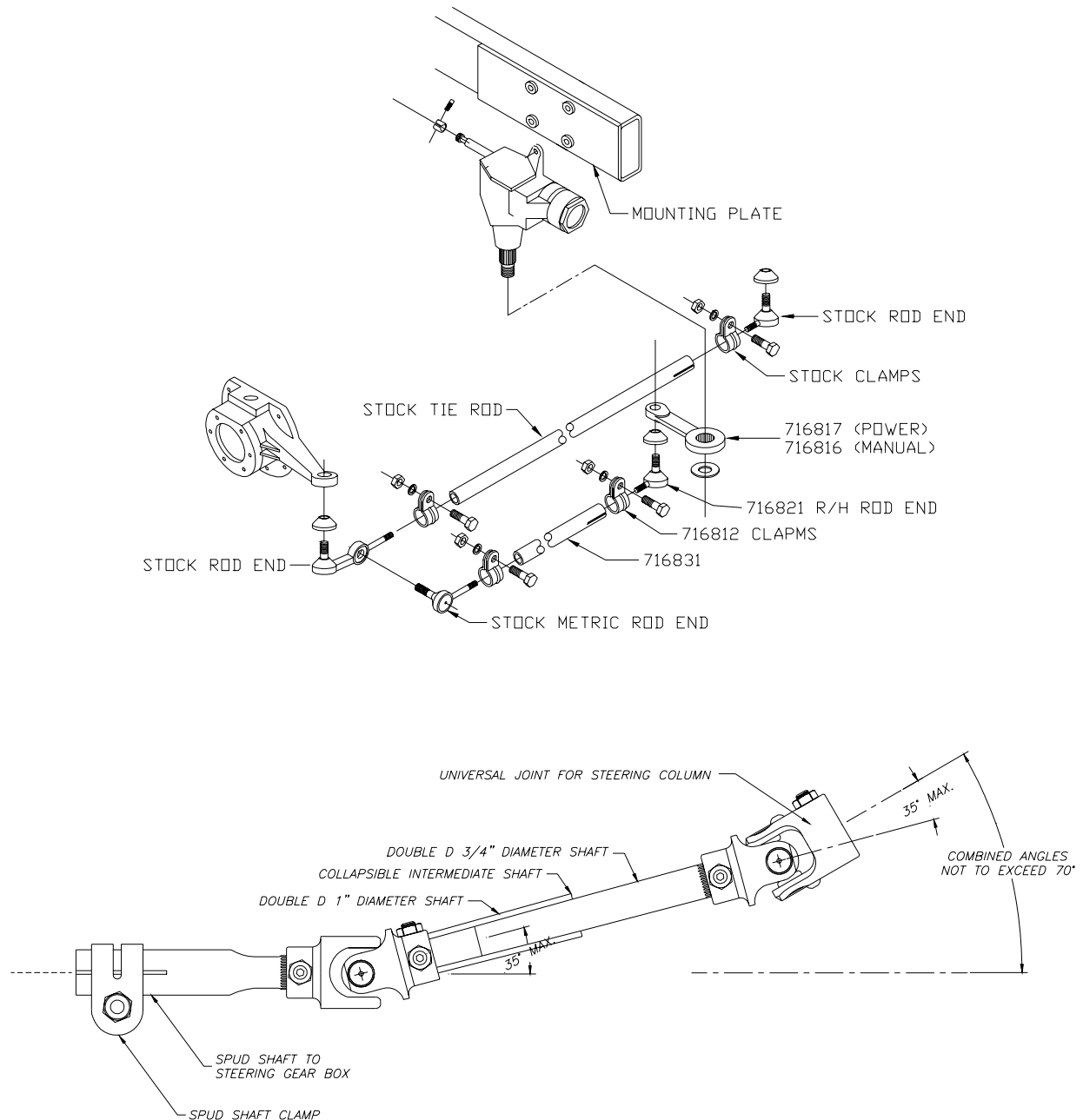

SPECIAL NOTE: The components packaged in this kit have been assembled and machined for specific type of conversions. Modifications to any of the components will void any possible warranty or return privileges. If you do not fully understand modifications or changes that will be required to complete your conversion, we strongly recommend that you contact our sales department for more information. This instruction sheet is only to be used for the assembly of Advance Adapter components. We recommend that a service manual pertaining to your vehicle be obtained for specific torque values, wiring diagrams and other related equipment. These manuals are normally available at automotive dealerships and parts stores.

MANUAL STEERING CONVERSION TOYOTA LAND CRUISER NEW DESIGN JAN '97

Installation Tips

We recommend Weldless DD and Double Splined universal joints for the best steering system.

Weldless DD universal joint features two set screws for maximum holding power. Position yoke, tighten set screws to mark the shaft. Remove yoke and drill the set point on the shaft. When installing the universal joint, set screws are tightened into the countersink mark, then tighten the jam nut and the shaft will not move. We recommend the use of Loctite.

Spline both ends (3/4"-36) universal joint is the preferred design, as it allows the shaft to be rotated in small increments during installation to properly align or phase the steering system. The same installation procedure as the Weldless DD should be used, or it is acceptable to simply grind a flat surface on the spline to let the set screw.

Optional Equipment

716863 - Collapsible Steering Shaft 3/4" DD X 1" DD
(comes without any universal joints)

716843 - Universal Joint (1" DD X 7/8")
716844 - Universal Joint (3/4" DD X .800" 36 spline)
716845 - Universal Joint (1" DD X 3/4" 36 spline)
716846 - Universal Joint (1" DD X .800" 36 spline)
716848 - Universal Joint (3/4" DD X 1" 48 spline)
716849 - Universal Joint (3/4" DD X 1" DD)
716850 - Universal Joint (3/4" DD X 3/4" 36 spline)
716851 - Universal Joint (3/4" DD X 3/4" DD)
716852 - Universal Joint (3/4" 36 spline X 3/4" 36 Spline)



A FEW NOTES

****Phasing**-Keep the forks of the yokes closest to each other in line and parallel to the centerline of the shaft to avoid binding.

******Always use the **minimum angle** when designing your system - ideally 10 degrees or less, NEVER MORE THAN 35 DEGREES.

****NEVER WELD** a universal joint. Welding reduces the strength of the metal and can melt the needle bearing seal.

****BUFFING** creates a very attractive finish in a matter of minutes. It is very important not to buff the caps because over heating may damage the bearing seals.

SPECIAL NOTE: The components packaged in this kit have been assembled and machined for specific type of conversions. Modifications to any of the components will void any possible warranty or return privileges. If you do not fully understand modifications or changes that will be required to complete your conversion, we strongly recommend that you contact our sales department for more information. This instruction sheet is only to be used for the assembly of Advance Adapter components. We recommend that a service manual pertaining to your vehicle be obtained for specific torque values, wiring diagrams and other related equipment. These manuals are normally available at automotive dealerships and parts stores.